

---

# Specialty Ball Bearings

Course No: M03-017

Credit: 3 PDH

---

Robert P. Tata, P.E.

---



Continuing Education and Development, Inc.  
22 Stonewall Court  
Woodcliff Lake, NJ 07677

P: (877) 322-5800  
[info@cedengineering.com](mailto:info@cedengineering.com)

---

# Specialty Ball Bearings

Copyright 2012

Robert Tata, B.M.S.E., P.E.

All Rights Reserved

## Introduction

Ball bearings are precision engineering components that are used primarily to support rotating shafts in mechanical equipment. They can be found in everything from personal computers to passenger cars. They are of simple design and can be manufactured in mass production quantities. They can support heavy loads over a wide speed range and do it virtually friction free. They come in many different sizes and shapes, are relatively inexpensive, and require little or no maintenance. They have predictable design lives and operating characteristics and are truly a valuable asset to today's rotating equipment industry.

Since ball bearings are of simple design and can support loads from multiple directions, they can be put to good use in a number of different shapes and sizes in both domestic and industrial products. This course will first discuss basic ball bearing design and characteristics. That will be followed by a review of some of the many variations of ball bearings that are used in today's products including some of the applications and advantages of each.

Contents

Page

Ball Bearing Description-----4

Ball Bearing Closures-----11

Maximum Capacity Bearings-----15

Adapter Bearings-----18

Farm Implement Bearings-----18

Two-Piece Inner Ring Bearings-----22

Angular Contact Ball Bearings-----27

Integral Shaft Bearings-----30

Double Row Ball Bearings-----32

Automotive Ball Bearings-----35

## Ball Bearing Description

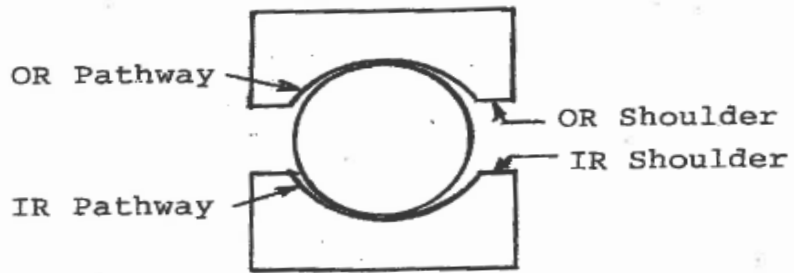
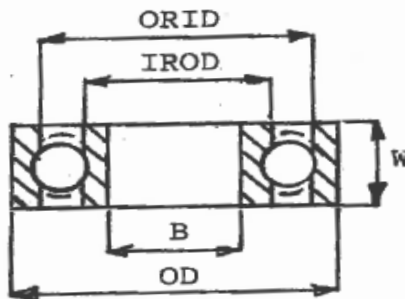
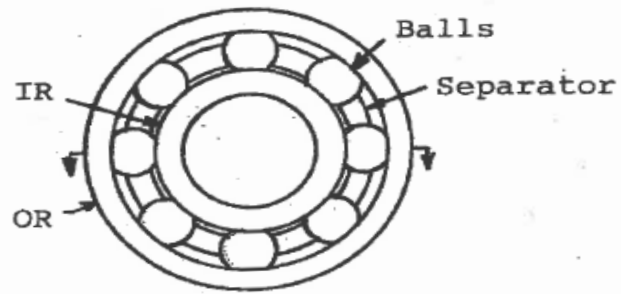
A ball bearing consists of an inner ring, an outer ring, a complement of balls, and a separator. (See Figure 1.) The inner ring outside diameter (IROD) and the outer ring inside diameter (ORID) have a groove in which the balls revolve around. This groove is commonly called the pathway. The raised surface on each side of the pathway is called the shoulder. The balls are held equally spaced around the annulus of the bearing by the separator. The basic dimensions of the bearing are the inner ring inside diameter or bore (B), the outer ring outside diameter (OD), and the width (W). The basic or standard ball bearing is called the “radial” ball bearing. It is assembled according to the “Conrad” method as shown in Figure 2. In order to accomplish this method of assembly; a limited number of balls can be designed into the bearing. This makes radial ball bearings able to support less load than ball bearings with a full complement of balls (discussed later).

Radial ball bearings support both radial and thrust loads. Radial loads act perpendicular to the bearing axis of rotation while thrust loads act parallel to the bearing axis of rotation. (See Figure 3.) This is a major advantage of using radial ball bearings over cylindrical roller bearings in that cylindrical roller bearings can support high radial loads but are restricted in the amount of thrust load they can support. Cylindrical roller bearings, as the name suggests, have rollers that are the shape of cylinders. The roller flat ends do not support thrust loads as efficiently as do the spherical balls in ball bearings. (See Figure 4.)

Most ball bearings fall into three different series based on their cross-sectional area with the larger sizes being able to support heavier loads. (See Figure 5.) Commonly used radial ball bearings come in a very large size range starting with a bearing having a 4 millimeter (mm) bore (.1575 inch), 16 mm OD (.6299 inch), and 5 mm width (.1969 inch) to a bearing with a 180 mm bore (7.0866 inch), 280 mm OD (11.0236 inch), and 46 mm width (1.8110 inch). Although most bearings are manufactured to metric dimensions; bearings made to inch dimensions are also available. (See Figure 6.)

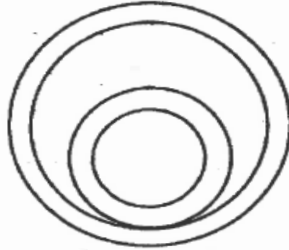
Figure 1

Radial Ball Bearing

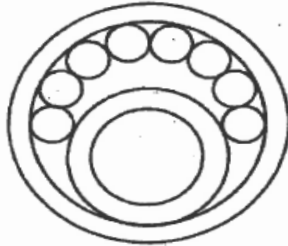


(Enlarged Section)

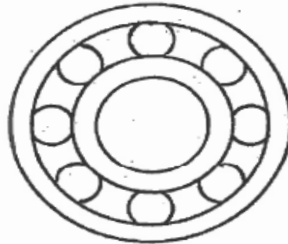
**Figure 2**  
**Conrad Assembly**



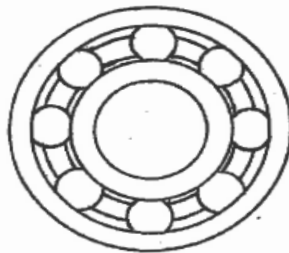
The IR is placed off-center inside the OR.



The balls are placed in the open space.



The IR is centered and the balls spaced.



The separator is installed.

Figure 3

Ball Bearing Loading

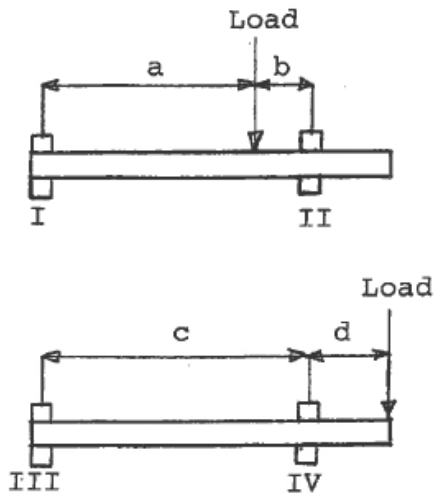
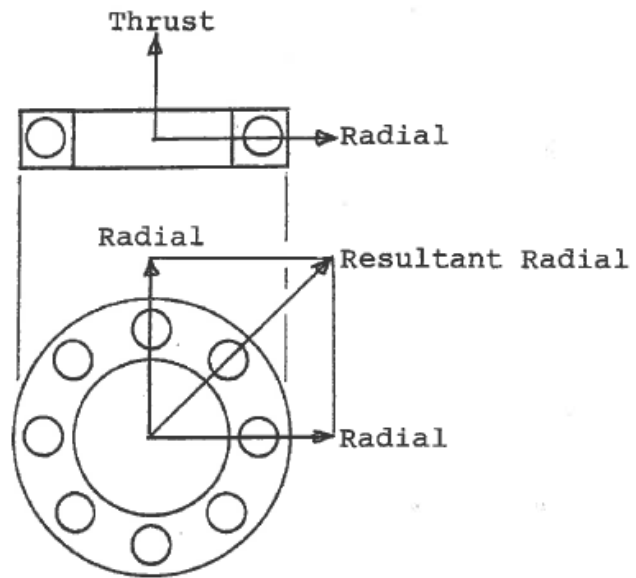
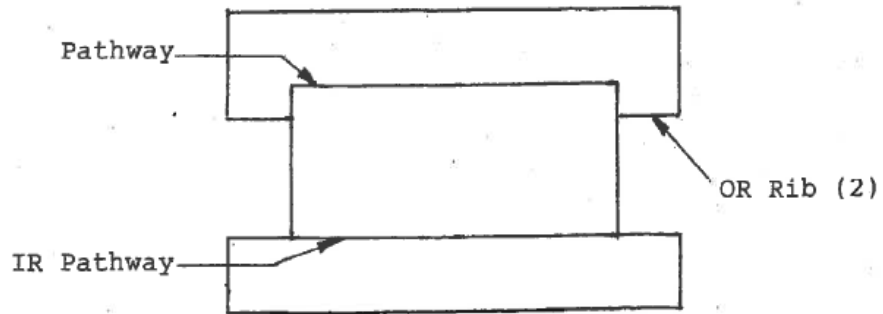
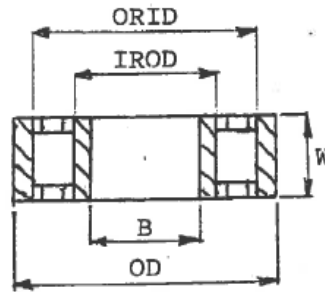
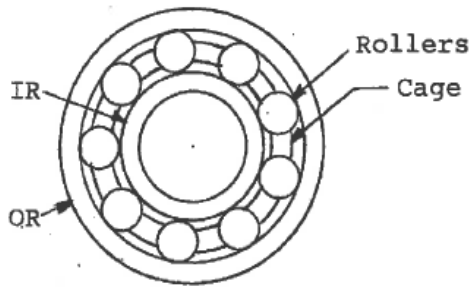




Figure 4

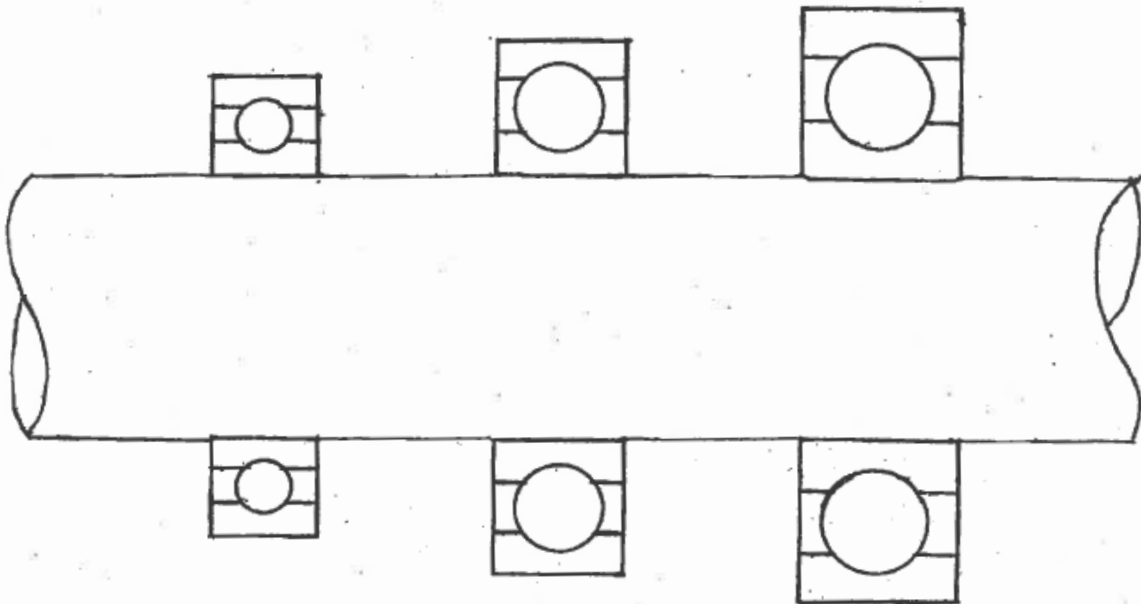
Cylindrical Roller Bearing



(Enlarged Section)

Figure 5

Ball Bearing Series



Extra Light  
Series

Bore  
35 mm

OD  
62 mm

Width  
14 mm

Balls  
11-5/16 in

Capacity  
950 lb

Light  
Series

Bore  
35 mm

OD  
72 mm

Width  
17 mm

Balls  
9-15/32 in

Capacity  
1900 lb

Medium  
Series

Bore  
35 mm

OD  
80 mm

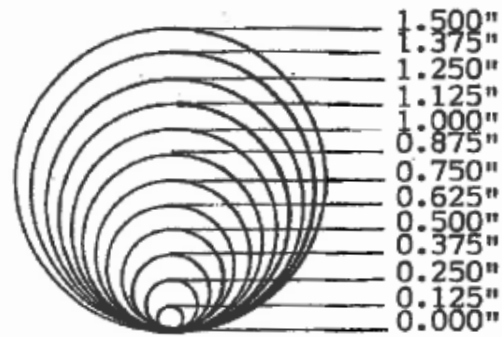
Width  
21 mm

Balls  
8-9/16 in

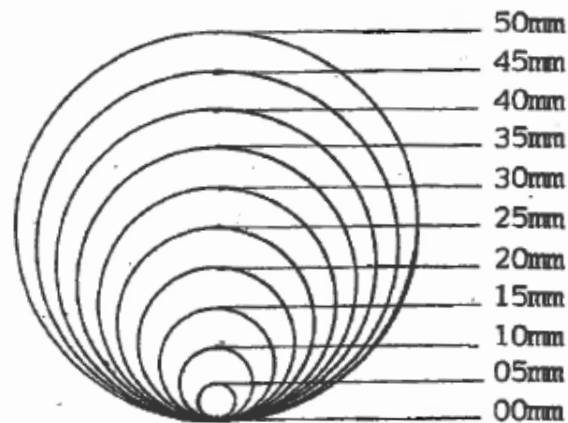
Capacity  
2400 lb

Figure 6

Ball Bearing Bore Sizes



Relative Bore Sizes  
Inch Series  
Full Scale



Relative Bore Sizes  
Metric Series  
Full Scale

Figure 7 has two application drawings of mechanical assemblies using radial ball bearings. The upper unit is of a flexible shaft handpiece and the lower unit is the flexible shaft handpiece drive unit. The handpiece must be small enough to fit inside a clasped hand and support loads from a variety of different tools that are attached to the left end. The handpiece right radial ball bearing is clamped both on the shaft and in the housing to locate the shaft and support thrust loads. The smaller left bearing is free to float in the housing to allow for manufacturing tolerances and shaft thermal expansion and is used for radial support only. The clamped spacer between the two bearings adds rigidity to the relatively small shaft.

The lower drawing on Figure 7 is the motorized drive unit for the upper assembly. The upper shaft on the drive unit has the right bearing clamped axially and the left bearing free to float to accommodate manufacturing tolerances and thermal expansion. The radial bearings on the lower motor are free to float as end play is not critical on this shaft.

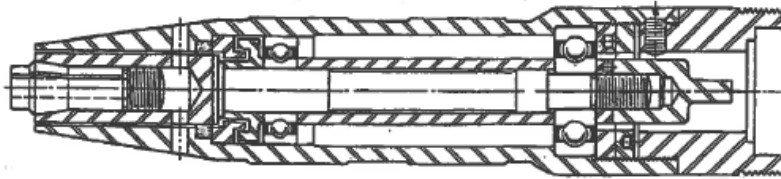
### Ball Bearing Closures

A version of a radial ball bearing commonly used is one with closures or seals. The seals can be installed on one or both sides of a bearing to contain grease lubricant, to protect against dirt or foreign object entry, or to control the flow of lubricant entry when the bearing is exposed to an oil sump. Grease and double sealed bearings offer maintenance free operation for the life of a ball bearing.

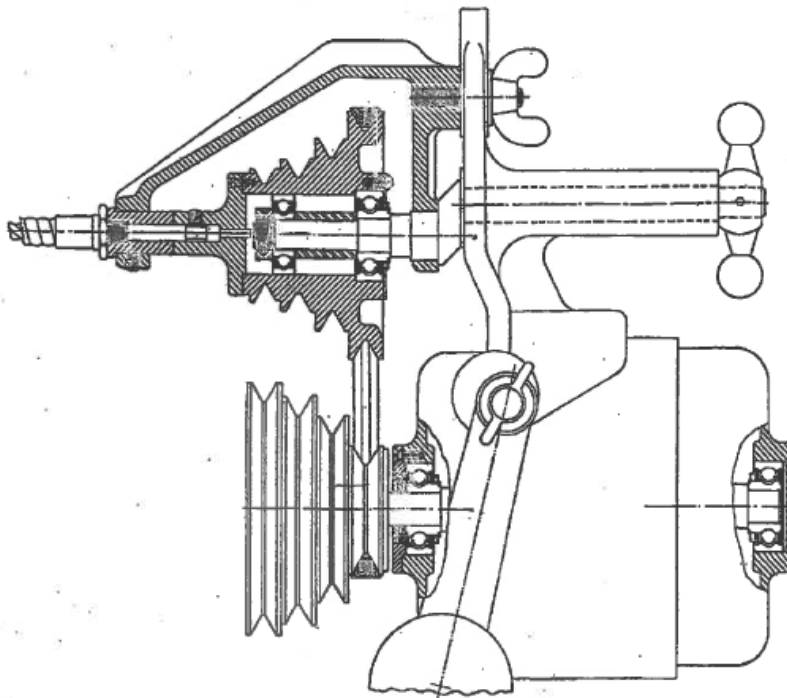
At the top of Figure 8 is a drawing of a radial ball bearing with a standard synthetic rubber lip seal installed on one side. The rubber is molded around a flat steel ring insert which imparts rigidity and strength to the construction and helps to control seal lip pressure which is needed to accommodate movements of the inner ring with respect to the outer ring. The seal is snapped into a groove in the outer ring where the rubber provides a leak proof joint. A standard design rubber seal has an operating temperature range of -65°F to 225°F. There are other similar materials available for higher temperature operation.

**Figure 7**

**Radial Ball Bearing Application**

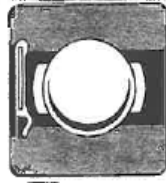


**Flexible Shaft Handpiece**

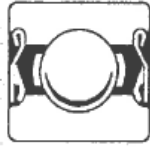


**Flexible Shaft Drive Unit**

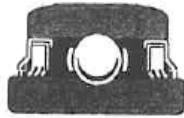
Figure 8  
Ball Bearings Closures



Standard Rubber Lip Seal



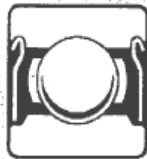
Lip Seal With Outer Guard



Triple Lip Seal With Guard



Felt Seal



Double Shields

The limiting high speed operation of bearings with seals is reduced somewhat because of the drag of the seal. The ability to design and assemble effective sealing elements on both sides of a standard width radial bearing without going outside the bearing envelope and to grease lubricate the bearing for a lifetime of operation, offers a distinct advantage to the designer in packaging mechanical equipment over having to provide an alternate means of lubrication for the bearing or to provide extra space to accommodate an extra wide sealed bearing.

The second drawing on Figure 8 has another version of the single lip seal. It consists of a steel shield on the outside with a rubber lip seal molded on the lower inside. The metal is positioned on the outside to protect the bearing internals from hard foreign object entry. The metal is crimped into a groove on the outer ring and becomes a permanent part of the bearing.

The third drawing on Figure 8 depicts a triple lip seal. This seal was developed for extremely severe duty such as in the farm equipment field. It is basically three single lips molded into a one-piece unit and bonded to a metal outer case which is press fitted into the outer ring inner diameter. It has the same metal outer piece which protects against hard foreign object entry. The three lips ride on the inner ring outside diameter with a higher sealing pressure than the notch riding seal lips shown above; consequently, this seal can be used for lower speeds only.

The fourth drawing on Figure 8 is of a felt seal. The felt seal element is contained inside a two-piece unit that is crimped into the outer ring inside diameter. The felt inside diameter rides on an extended section of the inner ring outside diameter. Operating temperature of this seal is 275°F maximum which is the charring temperature of the felt element. The limiting speed of bearings with felt seals is higher than all other seals shown.

The bearing shown on the fifth drawing of Figure 8 has two shields. It is the simplest form of bearing enclosures. It is a one piece metal element that is crimped into the outer ring inner diameter notch. The shield inner diameter does not contact the inner ring outer diameter but is positioned very close to provide as an effective seal as possible without making contact. The shield is used not only to contain grease inside a bearing but is used to limit the amount of lubricant that

can enter the bearing when exposed to an oil sump. Limiting speed of shielded bearings is not affected since there is no contact with the inner ring.

Figure 9 shows the mounting arrangements for radial ball bearings with closures. The upper drawing is a sketch of an adapter bearing with two lip seals for sealing grease lubricant in a clean, open environment. Adapter bearings are used in industrial applications and are discussed later.

The second drawing has a shaft supported by two radial ball bearings with felt seals for high speed, light load application. The felt seals serve to exclude light gear debris and transmission fluid from entering the bearing and washing away the grease lubricant. The right bearing inner ring is clamped axially while both bearings are free to float in the housing. The spring behind the left bearing puts a slight axial preload on both bearings and assures positive contact between the balls and rings preventing slippage at high speeds and light loads.

The third drawing on Figure 9 has a radial ball bearing with one shield mounted beside a transmission gear. The inner ring is clamped tight while the outer ring is retained by a bearing cap and a snap ring; both features are necessary to positively locate the gear. The shield prevents gear debris and excessive amounts of transmission fluid from entering the grease lubricated bearing.

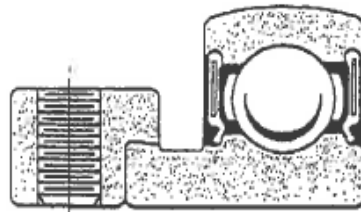
### Maximum Capacity Bearings

Maximum capacity ball bearings have the same radial construction as the Conrad type; however, as seen on Figure 10, a ball loading groove is cut into the shoulder of each ring. The loading groove, or “filling notch” as it is sometimes called, permits more balls to be assembled into the bearing than possible with the Conrad method. The location of the loading groove is accurately controlled so the bottom of the groove does not extend to the principle load supporting area of the pathway. The design achieves the maximum radial capacity possible in a single row bearing with a separator. Because the loading grooves interrupt the pathway shoulders, bearing thrust capacity is limited. Moderate thrust loads can be supported if accompanied by substantial radial loading.

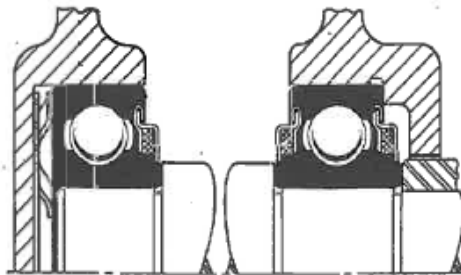


**Figure 9**

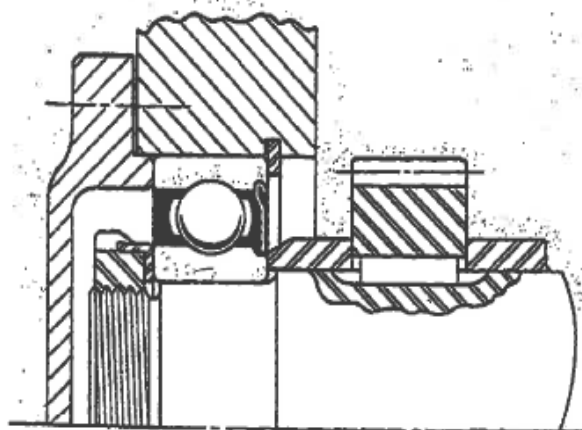
**Ball Bearing Closures**



**Dual Lip Seals**

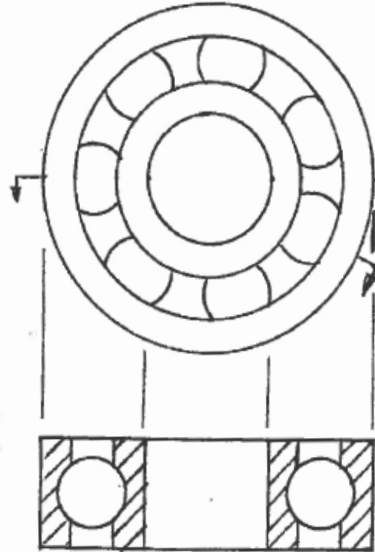


**Single & Dual Felt Seals**

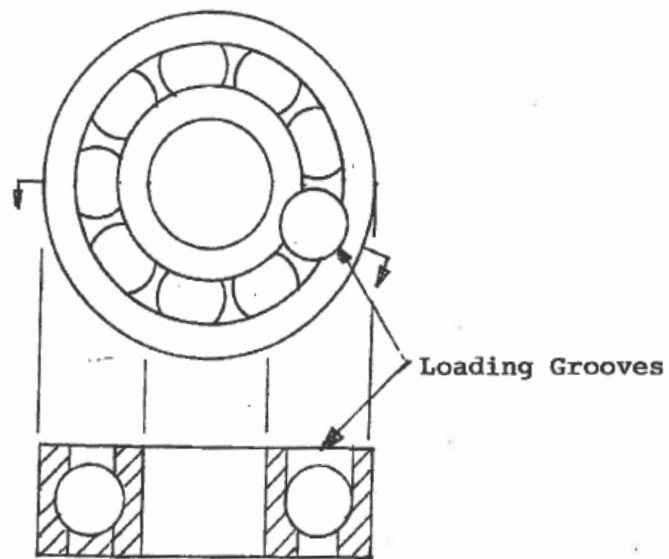


**Single Shield**

Figure 10  
Maximum Capacity Ball Bearing



Radial Ball Bearing  
7-13/32 in Balls  
Capacity = 1200 lb



Maximum Capacity Version  
of Above Bearing  
9-13/32 in Balls  
Capacity = 1440 lb

## Adapter Bearings

Adapter bearings are a form of radial ball bearings that are prelubricated, sealed, and precision manufactured and are made to support standard commercial steel shafting. (See Figure 11.) They are designed for installations where loads and speeds are moderate and concentricity requirements not too stringent such as in pillow blocks supporting rotating steel rod in a manufacturing environment.

Adapter bearings have an extended inner ring on which there is an integral cam flange eccentric to the bearing bore. When the locking collar, which also has an eccentric cam, is engaged and rotated on the cam flange, the bearing inner ring is securely clamped on the shaft. This type of inner clamping readily accommodates slight tolerance variations in commercial steel shafting. The eccentric collar mounting is not recommended for use under conditions of reverse rotation, oscillation, or severe vibration. Adapter bearings can be furnished for either a cylindrical or spherical outer diameter as shown on Figure 11. The spherical OD version allows the bearing to accommodate misalignment.

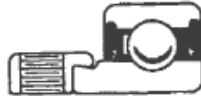
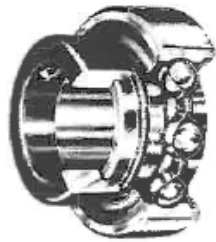
Relube adapter bearings are shown on Figure 12. A two-piece flange is clamped on the bearing outer ring. It has a fitting for lubricating the bearing for those applications where the initial grease fill is inadequate. The flanges of this type of adapter ball bearing are designed to be face mounted rather than outside diameter mounted used for those shown on Figure 11.

## Farm Implement Bearings

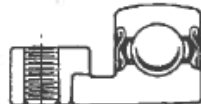
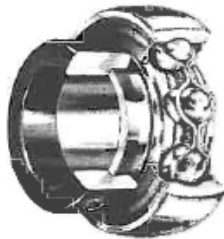
A harrow is a piece of farm equipment with discs or spikes that is used to break up hard ground. Figure 13 has an image of a disc harrow bar ball bearing. Disc harrow ball bearings have extra thick sections to provide dependable service under severe operating conditions. Most are supplied with a square bore but some are also available with a round bore. Triple lip seals with an outer metal shield are mounted on the bearings because of the severe operating environment. The bearing can be furnished with a spherical outer diameter as shown on Figure 13 for self-aligning applications.

**Figure 11**

**Adapter Bearings**



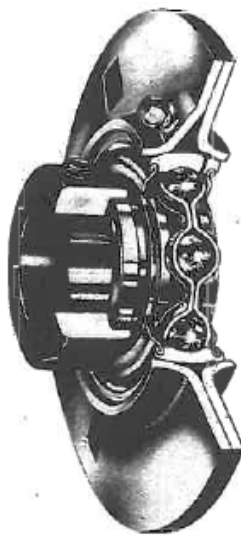
**Cylindrical OD**



**Spherical OD**

**Figure 12**

**Relube Adapter Bearings**

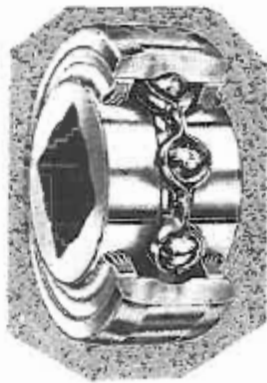


**Figure 13**

**Disc Harrow Bearing**



**Cylindrical OD**



**Spherical OD**

A tine is a prong that is a part of a piece of farm equipment that is used to rake hay. Figure 14 has an image of a hay rake tine bar bearing. The bearing is a precision radial type with a special stud mounted in the bore for assembly. The bearing does not need a rear seal which is located in an enclosed area.

Figure 15 has a cam follower ball bearing that is engineered to run on a conveyor or track. They are designed with a crowned extra-heavy outer ring to accommodate misalignment and to resist heavy shock loads encountered in the application.

Greased and sealed precision ball bearings eliminate the need for lubricant lines in conveyor systems thus reducing the cost of maintenance. Figure 16 has an image of a conveyor ball bearing. One end has a double lip seal with shield and the other is completely closed with a crimped in place full size end cover. The bore is splined to accept a mating splined stub shaft.

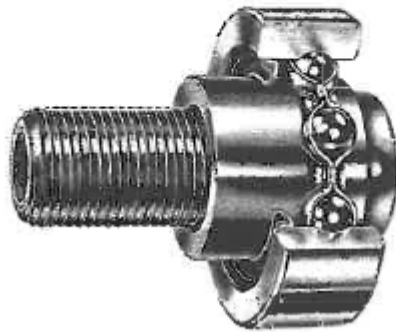
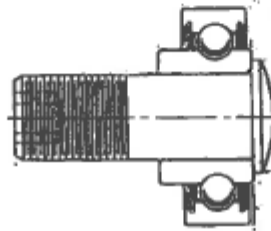
### Two- Piece Inner Ring Bearings

Figure 17 has a sketch of a two piece inner ring ball bearing. It combines the features of the Conrad, maximum capacity, and angular contact ball bearings as follows:

1. A maximum number of balls may be assembled into the bearing for the highest load support.
2. Very deep pathways are ground into the rings for support of higher thrust loads in either direction.
3. A one piece, light weight, symmetrical separator can be used possessing low friction, strength and rigidity.
4. Pathway geometry may be altered to achieve less inner ring axial movement with respect to radial movement with the outer ring fixed.
5. A groove can be furnished on the inner ring or outer ring to be used to attach a tool for bearing removal.

**Figure 14**

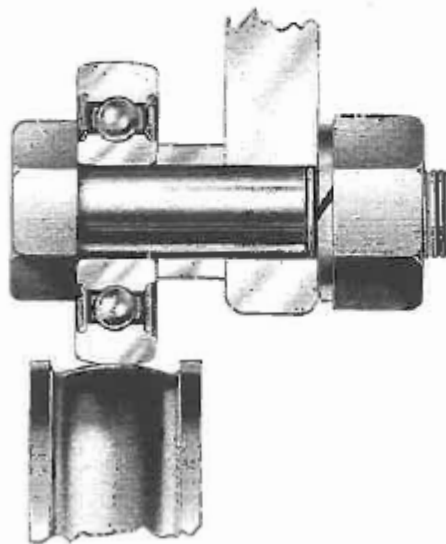
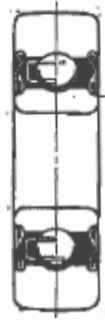
**Hay Rake Tine Bar Bearing**





**Figure 15**

**Cam Follower Bearing**



**Figure 16**  
**Conveyor Bearing**

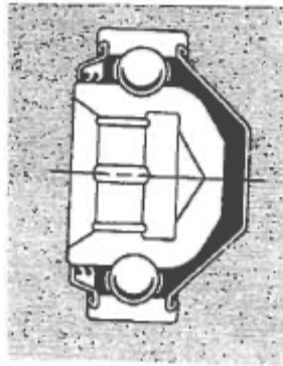
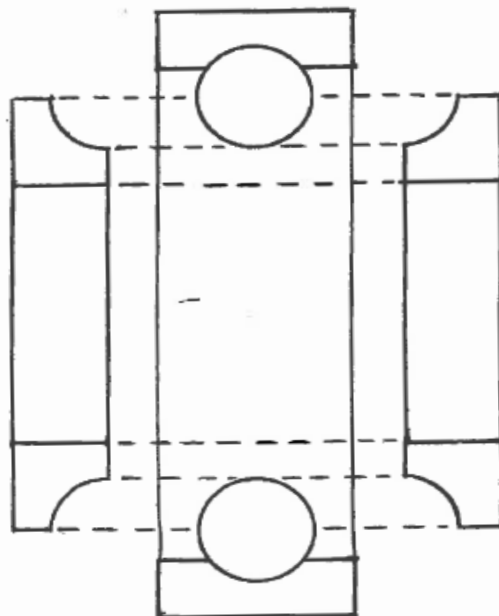
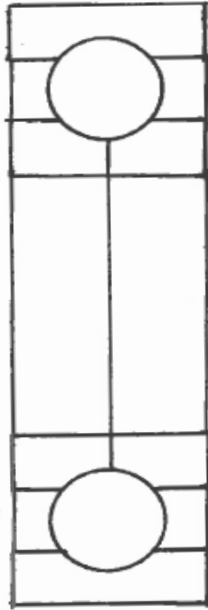


Figure 17

Split Inner Ring Bearing



## Angular Contact Ball Bearings

Angular contact ball bearings are single row ball bearings designed so the line of contact between balls and pathways is at an angle to a plane perpendicular to the bearing axis of rotation. The angle is called the contact angle and is shown at the top of Figure 18 as “a”. One side of the outer ring has a large part of the shoulder removed. The inner ring and full complement of balls are assembled by heating the outer ring. When cooled the bearing is non-separable. The resulting design with a maximum capacity of balls and one standard height outer ring shoulder can support more unidirectional thrust load and has more axial rigidity than any other type of single row ball bearing.

Angular contact ball bearings are frequently mounted together in pairs. The second sketch on Figure 18 has two angular contact bearings in what is referred to as “back-to-back” mounting. This arrangement provides resistance to overturning moments and shaft angular deflection. The contact angle lines diverge as they approach the bearing centerline. The distance between the points where the contact angle lines intersect the bearing centerline is called the “effective spread” giving the bearings the ability to support high overturning moment loading and shaft deflection.

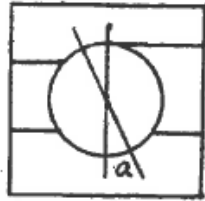
The third sketch on Figure 18 is of two angular contact bearings mounted “face-to-face”. In this arrangement, the contact line extensions converge when drawn to the bearing centerline. This decreases the ability of the bearings to resist overturning moments and shaft deflection. This type of mounting is preferred when a slight amount of housing misalignment or shaft bending is expected.

The fourth sketch on Figure 18 is called “tandem” mounting. It is used when there is a heavy unidirectional thrust load. More than two bearings can be mounted in tandem when the thrust load is heavier than what two bearings can support.

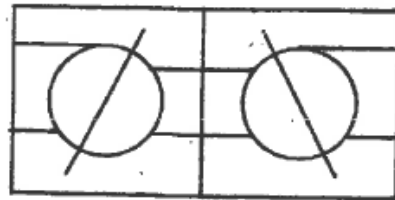
Figure 19 has typical mountings for angular contact bearing pairs. The top drawing depicts back-to-back mounting. The inner rings are clamped axially. The outer rings are free to float in the housing. This type of mounting provides resistance to overturning moment loading and shaft deflection.

Figure 18

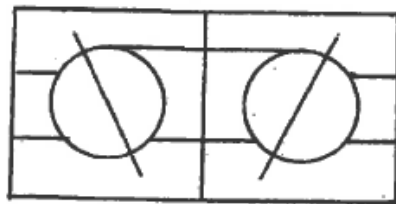
Angular Contact Ball Bearing



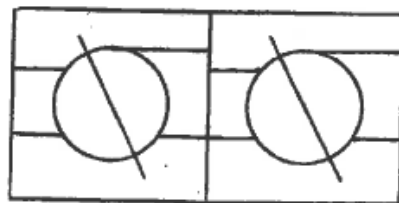
Contact Angle "a"



Back-to-Back Mounting

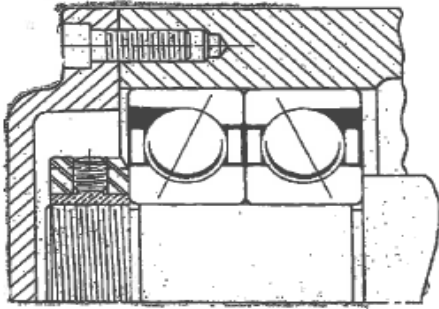


Face-to-Face Mounting

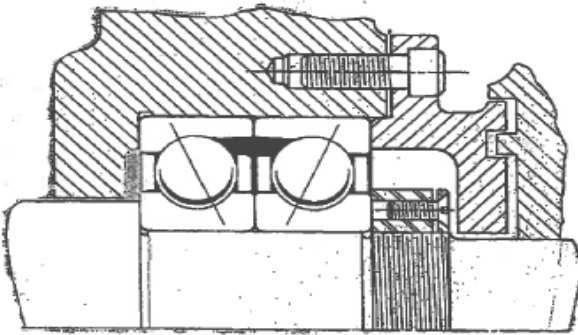


Tandem Mounting

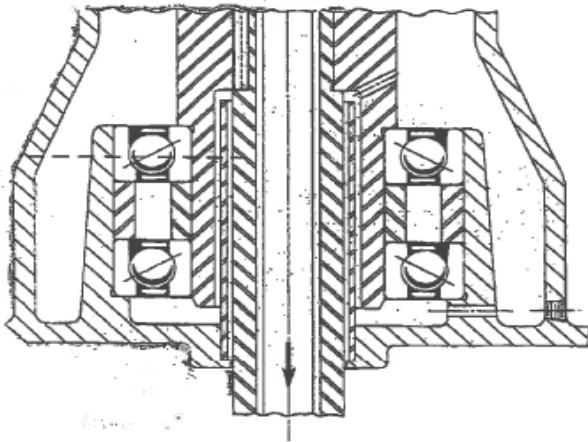
**Figure 19**  
**Angular Contact Bearing Mounting**



**Back-to-Back Mounting**



**Face-to-Face Mounting**



**Tandem Mounting**

The angular rigidity of this type of mounting requires that concentricity and squareness of housing and shaft bearing contact surfaces be of extreme accuracy.

The middle drawing on Figure 19 has two angular contact bearings mounted face-to-face. Both the inner and outer rings are clamped axially. This arrangement tolerates shaft misalignment rather than try to resist it like back-to-back.

The lower drawing on Figure 19 is of two angular contact bearings mounted in tandem but separated by a sleeve. The separation provides more shaft angular rigidity. This type of mounting provides support to heavy one-direction thrust loading.

Figure 20 has examples of machine tool bearing mountings. The top drawing has a single shielded radial ball bearing supporting a gearshaft. The inner and outer rings are clamped for axial gear location.

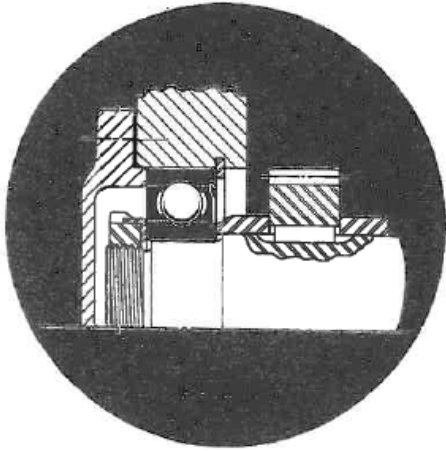
The middle figure of Figure 20 has two angular contact bearings supporting the work end of a machine tool spindle. Both the inner and outer rings are clamped together through equally length spacers. The bearing ring faces are offset ground so the clamping puts a preload on the bearings. The preload and the spacing between the bearings stiffen the shaft and provide support against overturning moments. These features add precision to the work being machined by the tool.

The lower image on Figure 20 features three angular contact bearings supporting a machine tool spindle. The face-to-face mounted pair are at the forward end and are preloaded through spacers by the rear angular contact bearing. This arrangement provides good radial and axial support.

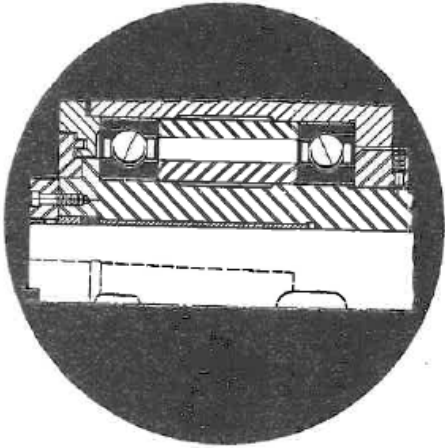
### Integral Shaft Bearings

The integral shaft ball bearing is designed with both inner ring pathways ground directly on a steel shaft. The shaft is heat-treated so that the ball pathways are hard enough to be capable of carrying high loads while the core is softer to be able to absorb high torque and shock loads. The heat treatment can be modified to leave the shaft extensions outside the bearing rows unhardened for threading

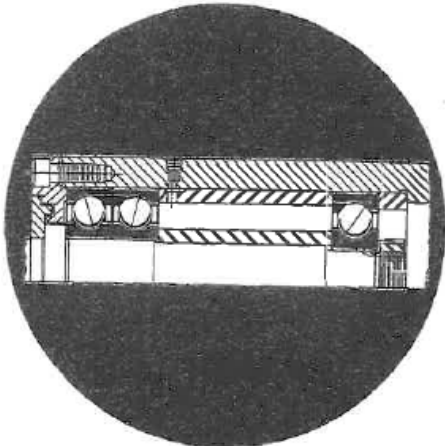
**Figure 20**  
**Machine Tool Bearing Mounting**



**Radial Ball Bearing**



**Angular Contact Bearings**



**Angular Contact Bearings**



or other machining operations. The elimination of the inner ring permits the use of a larger shaft which adds to the rigidity of the bearing assembly. The outer face is wide compared to standard double row ball bearings allowing a greater distance between ball rows in supporting high overturning moments. Both ends of the bearing are sealed and the wide spread ball rows allow the loading of a large quantity of grease for a lifetime of operation.

Figure 21 has a sketch of an integral shaft ball bearing along with typical shaft end machining features. Integral shaft bearings have many applications such as lawn tractors, table saws, fans, washers and dryers, wheel mounting, bench grinders, centrifugal pumps, and automotive fan and waterpumps.

### Double row ball bearings

Double row ball bearings have inner and outer rings with two pathways, two rows of balls, and two separators. In principle, they are two opposed angular contact bearings in an integral assembly. They can support a combination of heavy radial and thrust loads in an area that is narrower than two single row angular contact bearings.

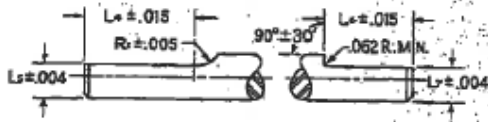
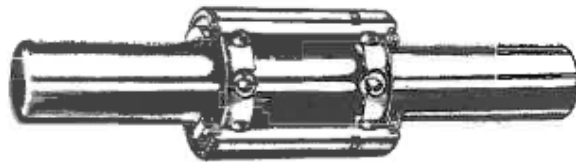
The top sketch on Figure 22 is of the rigid type where the lines of contact diverge toward the center of the bearing. This increases the effective spread between the two ball rows providing resistance to overturning moments and shaft bending. It is often used as a single bearing mounting in pulleys, gears, and wheels.

The second sketch on Figure 22 is of a double row ball bearing where the lines of contact converge toward the center of the bearing. This decreases the resistance of the bearing to angular deflection; therefore, this bearing should not be normally used in a single bearing mounting. This type of double row bearing is suited in heavily loaded applications where slight misalignment is expected.

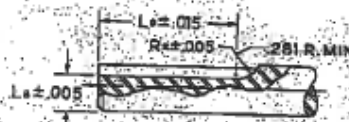
The third image on Figure 22 is a drawing of a mounted double row bearing with contact lines internally diverging. The inner and outer rings are positively clamped to resist reversing thrust loads.

Figure 21

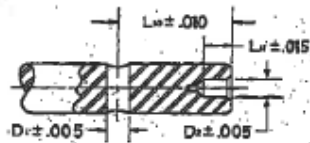
Integral Shaft Ball Bearing



flat



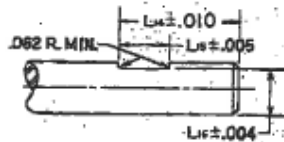
keyway



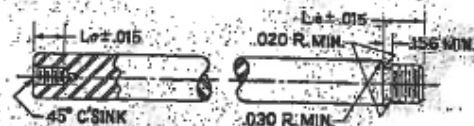
hole



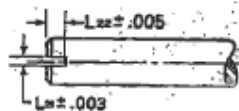
snap ring groove



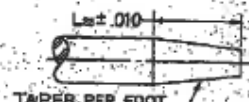
notch



thread



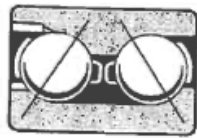
slot



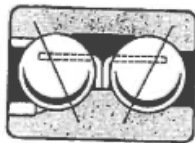
TAPER PER FOOT  
OR PER DEGREE  
taper

Figure 22

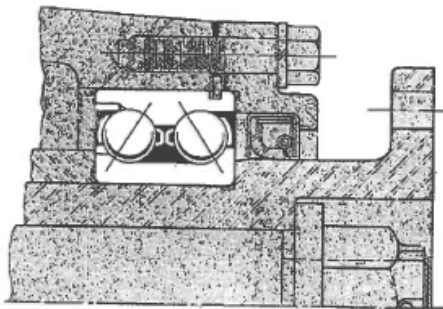
Double Row Ball Bearing



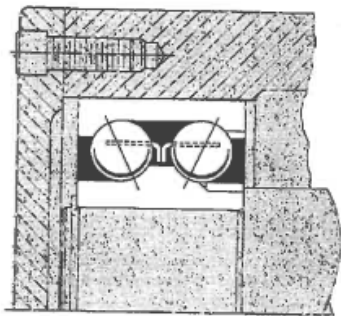
Internally Diverging



Internally Converging



Internally Diverging



Internally Converging

The fourth drawing on Figure 22 is a double row bearing with contact lines internally converging for rigid support of radial loads only. This arrangement is a soft support to overturning moments and can accommodate some misalignment.

### Automotive Ball Bearing Product

Figure 23 has a sketch of a drive shaft used in automotive drive trains. It connects the transmission to the drive wheels in modern front drive vehicles. It contains a Rzeppa universal joint which delivers power through a ball bearing row. This universal joint has the unique feature of delivering power at a constant velocity. Other commonly used universal joints do not deliver power at a constant velocity and have to be used in pairs so that the output velocity is the same as the input velocity.

Figure 24 has drawings of automotive vehicle water pumps incorporating an integral shaft ball bearing. On the upper drawing, the engine cooling fan and the waterpump drive pulley are a press fit on the bearing front shaft extension. The waterpump impeller is a press fit on the rear shaft extension. State of the art grease lubricant and seals provide a lifetime of operation for the waterpump.

The lower sketch is of a waterpump using an integral ball bearing with a stepped shaft. The pump drive hub is a press fit on the front shaft extension and the pump impeller is a press fit on the rear shaft extension. This waterpump version is used on front drive vehicles where the fan is electric motor driven.

Figure 25 has one of the more recent automotive wheel bearing advances. The new assemblies combine the spindle, hub, and two ball bearing rows into one lubricated-for-life and sealed package. The top drawing on Figure 25 is for non-drive wheels. It has a solid spindle while the lower drawing is for drive wheels and incorporates a female spline in the spindle.

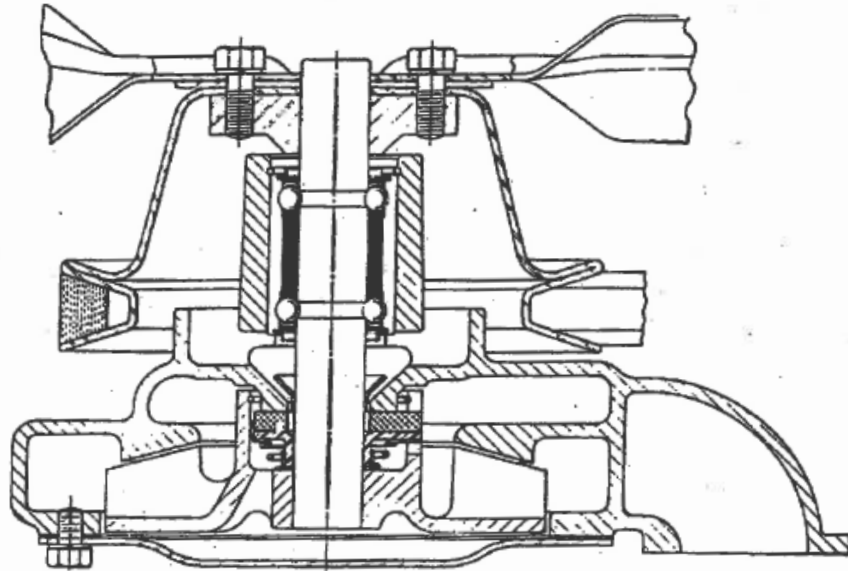
Figure 23

Rzeppa Universal Joint  
Drive Shaft

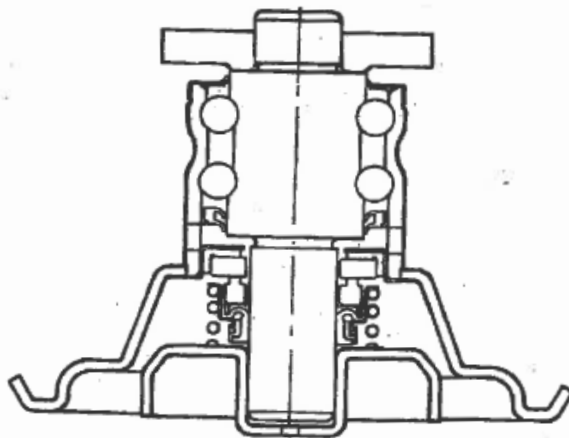


Figure 24

Automotive Waterpumps



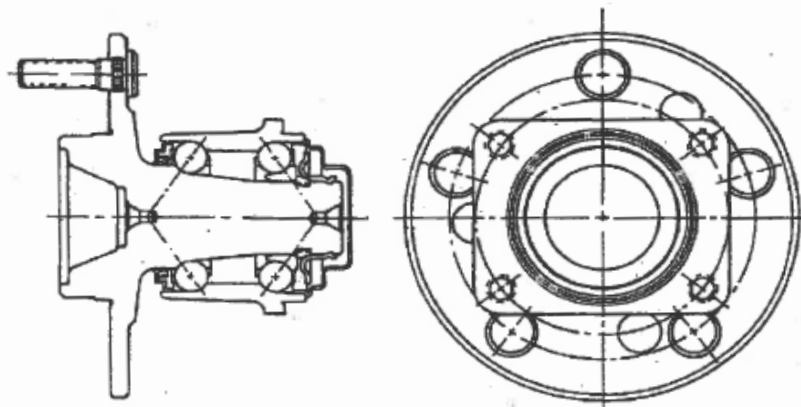
Traditional Automobile Waterpump  
With Integral Shaft Ball Bearing



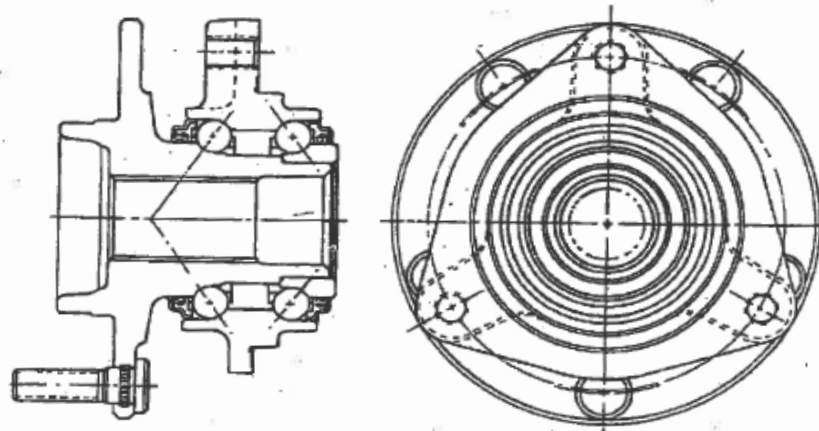
Later Version Waterpump  
With Stepped Shaft Bearing

Figure 25

Automotive Road Wheel  
Mounting Assemblies



Integral Non-Drive Wheel Bearing



Integral Drive Wheel Bearing